

BZ-Zyklon

Feststoffabscheider
Separator for separation of dust

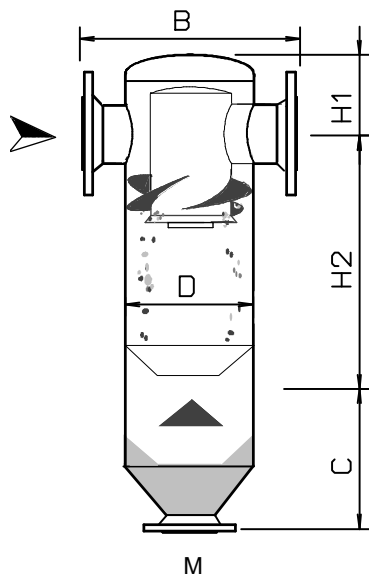

Standard 15 – 100 ohne Behälterflanschen

Standard 15 – 100
without vessel flanges

Material:

Stahl geschweißt, außen grundiert RAL 2002
Steel welding design, outside priming coat RAL 2002

Anschlüsse: Flansche nach EN 1092-1
connection: flanges acc. EN 1092-1

Abnahme: gem. DGRL 2014/68 + AD2000
Inspection: acc. PED 2014/68 + AD2000

Designtemperatur: -10 / +120 °C
Design temperature:

| Type BZ | DN | D Ø | H1 | H2 | C | B | M | barg | G-Ltr. | S - Ltr. | kg |
|---------|-----|-------|-----|-----|-----|-----|------|------|--------|----------|------|
| 15 | 15 | 63,5 | 90 | 150 | 170 | 200 | DN25 | 25 | 1,0 | 0,3 | 5,0 |
| 20 | 20 | 63,5 | 90 | 180 | 170 | 210 | DN25 | 25 | 1,1 | 0,3 | 5,9 |
| 25 | 25 | 101,6 | 100 | 225 | 200 | 240 | DN25 | 25 | 3,3 | 0,9 | 9,4 |
| 32 | 32 | 101,6 | 100 | 270 | 200 | 260 | DN25 | 25 | 3,7 | 0,9 | 11,3 |
| 40 | 40 | 127 | 110 | 290 | 210 | 340 | DN32 | 16 | 6,0 | 1,4 | 15 |
| 50 | 50 | 152,4 | 130 | 380 | 220 | 360 | DN32 | 16 | 10 | 2,0 | 22 |
| 65 | 65 | 177,8 | 140 | 485 | 250 | 400 | DN40 | 16 | 18 | 3,2 | 25 |
| 80 | 80 | 219,1 | 170 | 565 | 315 | 460 | DN40 | 10 | 33 | 6,0 | 35 |
| 100 | 100 | 267 | 190 | 665 | 360 | 520 | DN40 | 8 | 57 | 10 | 47 |

G-Ltr: Gesamtvolumen – volume / S-Ltr.: Sammelraum – collecting room
Sonderausführungen auf Anfrage / Special Version on request

